

RS RETRACTABLE SOOTBLOWER™

Severe duty tube bank cleaner

Others in the boiler cleaning industry have tried to imitate what Clyde Bergemann perfected years ago in the RS Retract. By copying our earlier design features such as the P-Chain electrical track and the top access for easy maintenance, our status as the leader in technology is widely acknowledged. However, the RS maintains its advantage with continuous improvement of our original designs, and now features several design standards not found in any other recovery sootblower.

The RS was designed with the severe conditions of a recovery boiler in mind. The design is similar to our US utility sootblower, with the addition of an internal steam purge line, and stainless steel lance tip for extended lance life. Industry leading design features include our balanced drive carriage that centers the gearbox evenly between the dual rack drives, providing balanced weight distribution. This design eliminates the frequent oil leaks and pinion failures found in "handed" sootblowers due to unbalanced weight distribution. The balanced drive also reduces the number of spare parts required for RS sootblowers.

The drive carriage is also a modular design, in which the upper gearbox is separated from the lower spindle housing by four, easily accessible bolts.

Compared to the single housing unit of competing sootblowers, gearbox removal is shortened by hours. The modular carriage also reduces thermal transfer from the high temperature cleaning medium to the gearbox oil, bearings and seals, which extends service life.

Short packing life is typically the #1 sootblower maintenance problem. The RS has the longest packing life of any retractable sootblower due to the stability of the four-roller carriage platform and superior packing technology. In addition, the patented Seal Pack™ live loaded packing system is standard on the RS allowing for quick and easy packing replacement via a pre-loaded cartridge, rather than stacking packing rings by hand, saving both time and money by maintenance personnel.



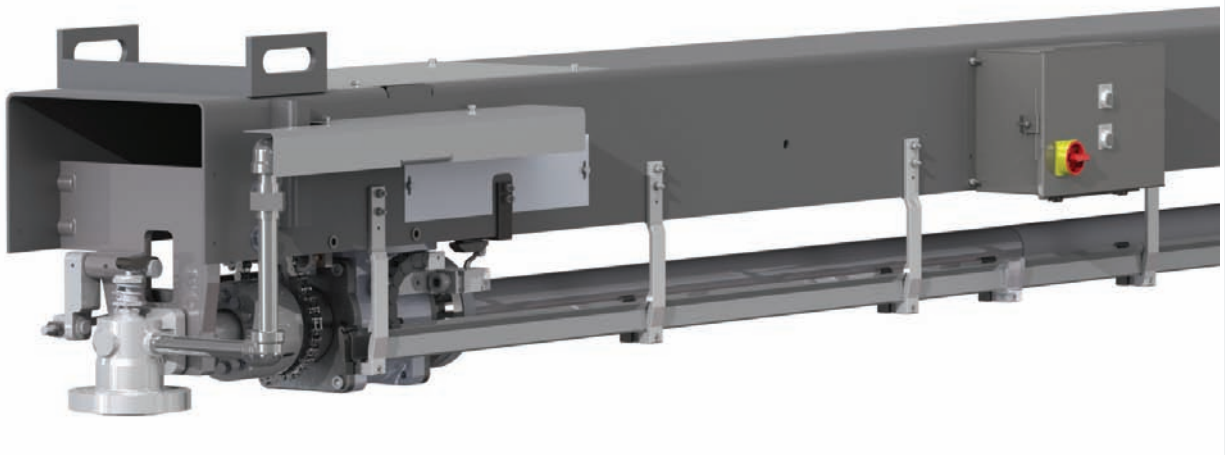

RS Retractable Sootblower™

The ultimate in cleaning performance and reliability

Additional standard features you will only find on Clyde Bergemann retracts are the hot-dipped galvanized housing, externally adjustable poppet valve and NEMA 4X junction box.

For the ultimate housing protection, with the industry's unique lifetime warranty, the RS is hot-dipped galvanized providing superior corrosion resistance.

The poppet valve incorporates an externally adjustable pressure disc, which allows precise, on-line setting of blowing pressures and eliminates the need for a lock-out/tag-out when adjusting blowing pressure.

Each RS is supplied with an integral NEMA 4X stainless steel junction box, complete with terminal strip, push buttons and rotary disconnect that meet the demanding environment of a boiler house.

The RS is also the leader in cleaning performance. Using the most effective cleaning nozzle on the market, striking power is maximized using a minimal amount of blowing media. Every RS also comes standard with the industry leading multiple progressive helix indexing system. By indexing inside the gearbox using a clutch, we eliminate problems such as pinion and gear rack failure found in other systems.

Benefits

- Balanced design drive system
- Modular drive carriage for easy maintenance
- Reduction in spare parts
- Extended packing life
- Hot-dip galvanized housing with lifetime warranty

Clyde Bergemann

Other

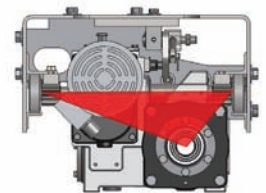
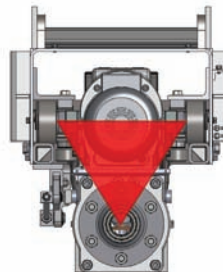

**Balanced Design
(Modular Construction)**

**Unbalanced Design
(Single Housing Construction)**



Clyde Bergemann Atlanta

4015 Presidential Parkway
Atlanta, GA 30340

T: 770-557-3600
F: 770-557-3651

QUALITY MANAGEMENT SYSTEM
CERTIFIED BY DNV

ISO 9001:2008

Internet: www.cbpg.com
eMail: info@us.cbpg.com